

GENERATOR APPLICATION TABLE					
M844LW3	20 KW	1800 RPM	3 PHASE	60 HZ	
M844LW3	20 KW	1800 RPM	1 PHASE	60 HZ	
M844LW3	16 KW	1500 RPM	3 PHASE	50 HZ	
M844LW3	16 KW	1500 RPM	1 PHASE	50 HZ	
M844DW3	16 KW	1800 RPM	3 PHASE	60 HZ	
M844DW3	16 KW	1800 RPM	1 PHASE	60 HZ	
M844DW3	14 KW	1500 RPM	3 PHASE	50 HZ	
M844DW3	14 KW	1500 RPM	1 PHASE	50 HZ	

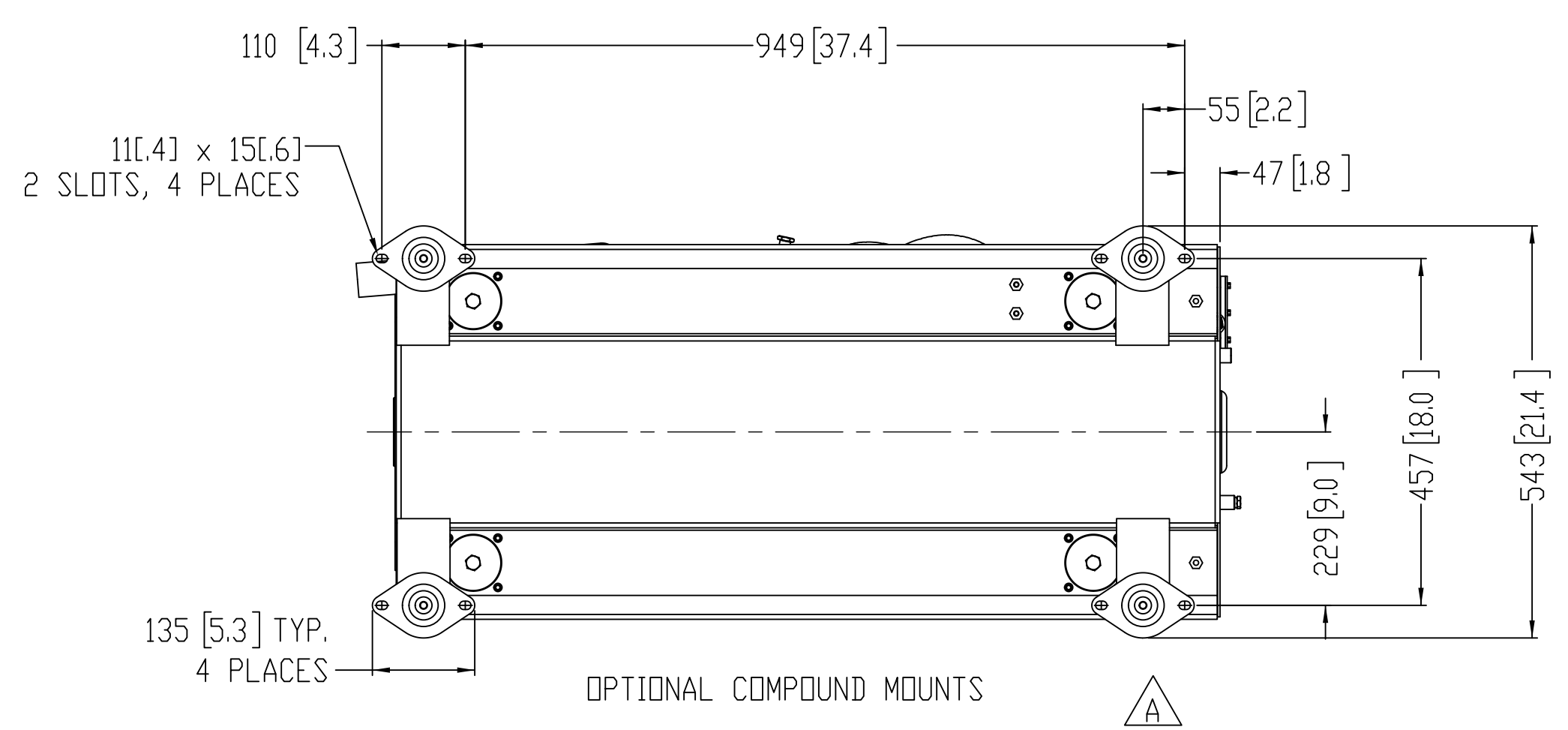
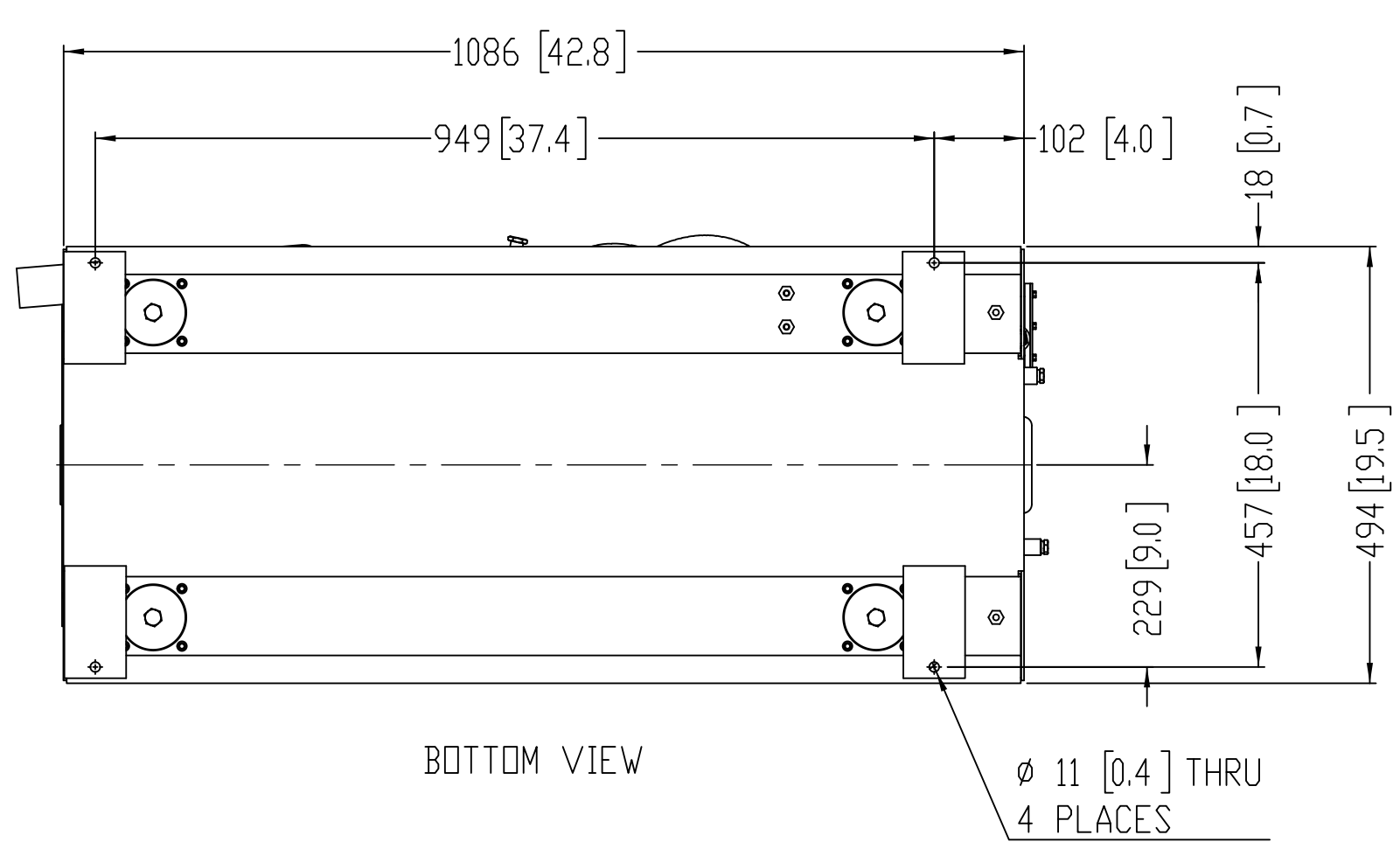
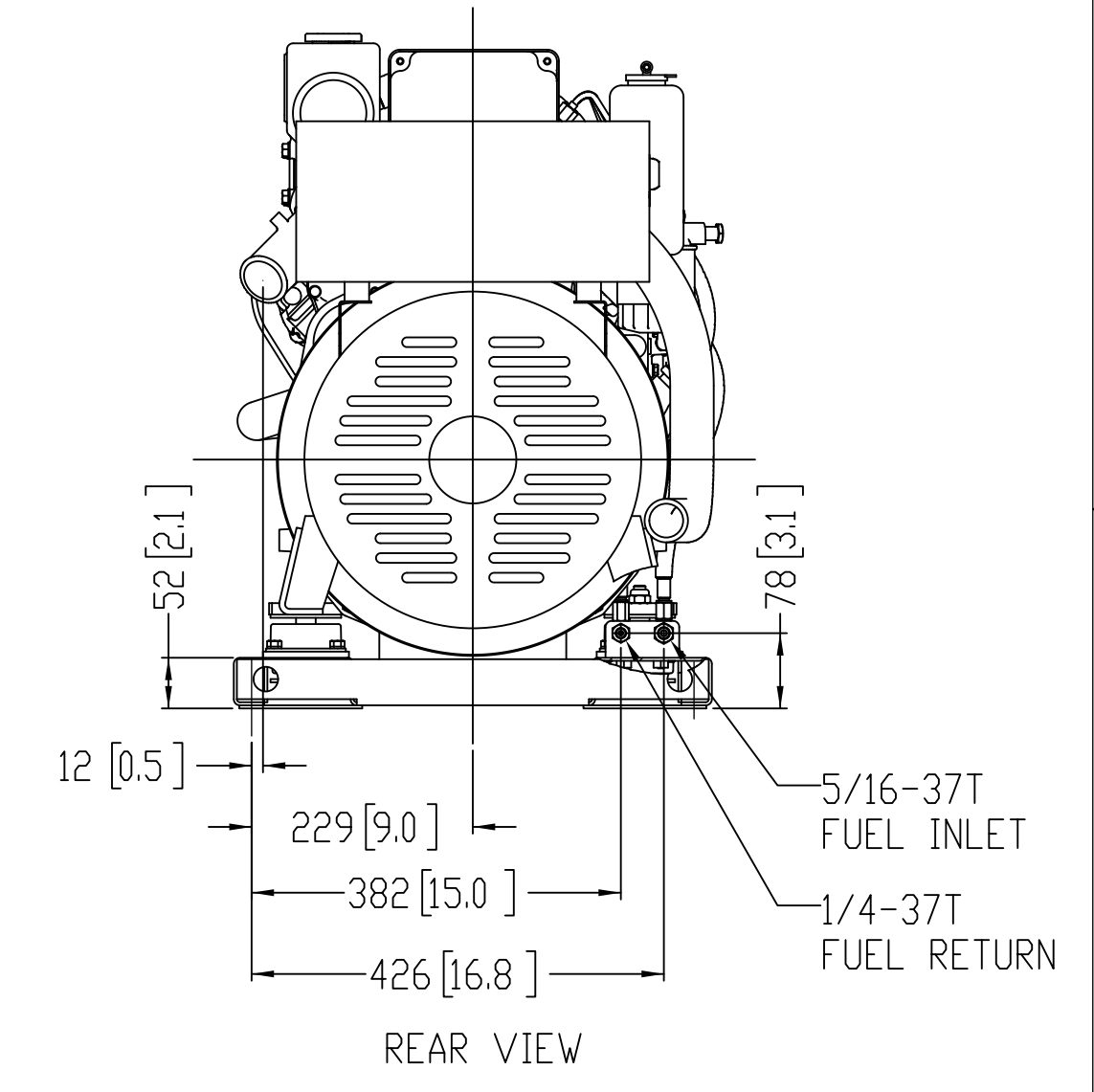
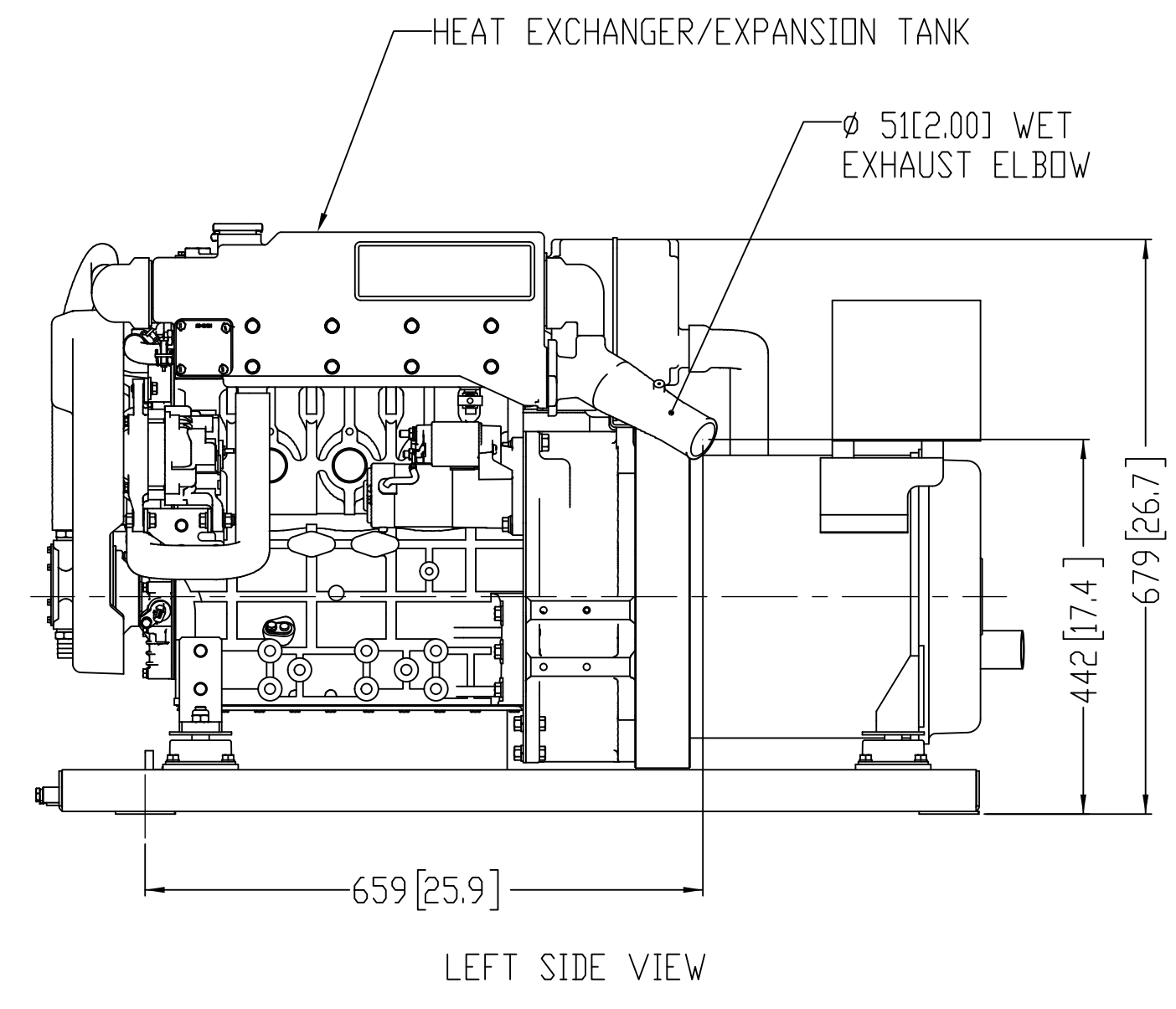
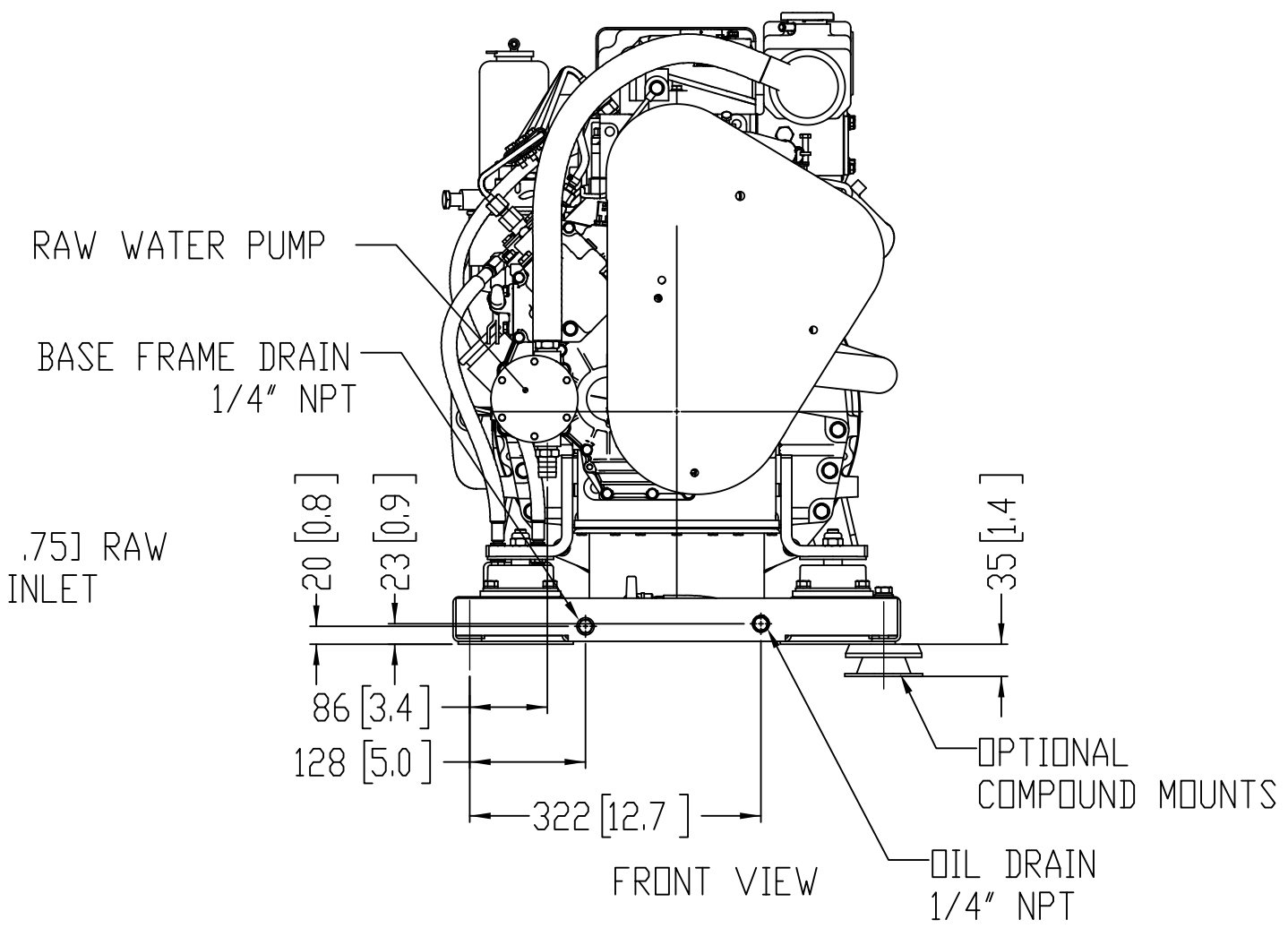
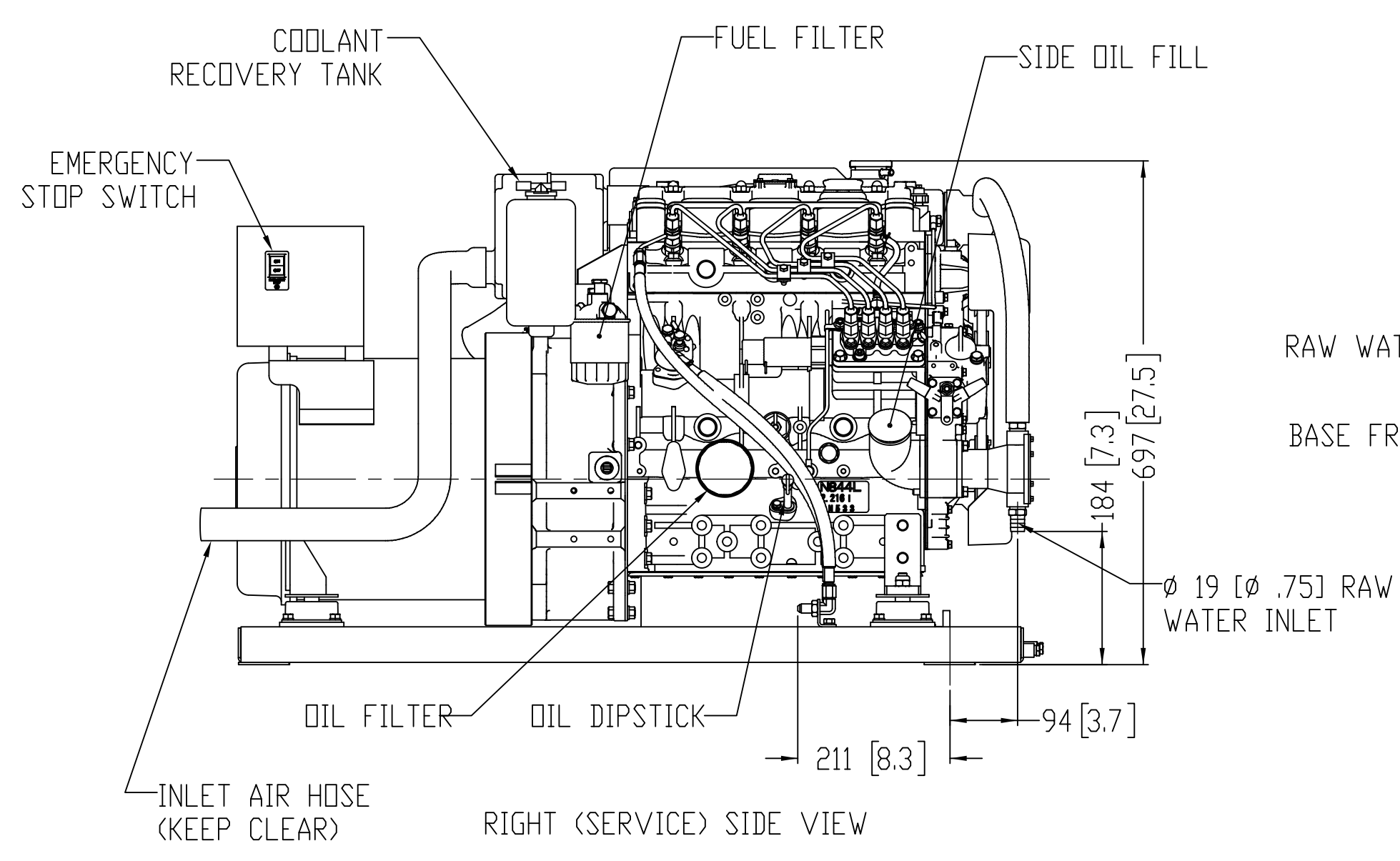

REV.	DESCRIPTION	DATE	BY	CHECKED
A	UPDATE VIEW FOR OPT COMPOUND MOUNTS, ECN #6507	1/21/2020	MK	LTP

NAME	DATE
GT	5/16/18

DRWN	CHECKED	ENG APPR	MFG APPR	DA	COMMENTS

NORTHERN LIGHTS		4420 14th AVE. N.W. Seattle, WA 98107 (206) 789-3880 www.northern-lights.com	
TITLE: INSTALLATION DIMENSIONS M844LW3 GEM SERIES			
SIZE: D	PART NO: SEE TABLE	DWG. NO: D-5104	REV: A
SCALE: 1:1	WEIGHT: 430 kg (948 lbs)	SHEET 1 OF 1	

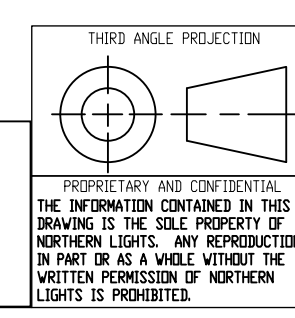

THE DIMENSIONS ON THIS DRAWING ARE SUBJECT TO CHANGE. PLEASE CONTACT NORTHERN LIGHTS INC. TO BE SURE YOU HAVE THE MOST CURRENT REVISION.

D-5104