



# Trans Atlantic Diesels, Inc.

## **BLEEDING THE FUEL SYSTEM & FILTER CHANGING HINTS 11/29/12**

This information primarily covers Perkins models 4.108/7 4.154, 4.236, 6.354 & some Westerbeke models that were based on Perkins Engines. These models all were fitted with CAV DPA rotary type injector pumps. If your engine is not a Perkins, the exact procedure & fittings at the pump may vary. However, the principals for removing air are similar. I suggest reading the whole article before commencing as there may be special information that pertains to your particular engine further down.

**TOOLS REQUIRED:** To change the secondary (on engine) fuel filter and bleed the system, you will require at a minimum: 7/16" wrench for the filter element removal, 5/16" wrench for pump bleed screws. 5/8" wrench for injector line Union nuts. A small bucket or cut off gallon jug, Some Ziploc bags and oil absorbent diapers. . This can be a "messy operation" so keep plenty of clean up materials handy.

**CHANGING THE FILTER:** Place a diaper inside the Ziploc bag. Place the open bag around the filter element, then loosen the element retaining bolt with a 7/16" wrench releasing the fuel and element into the bag. Clean the lower part of the bowl that retains the element. It should be free of sediment. Fit the new element using the new rubber sealing rings provided. There are 3 sealing rings, one in the upper housing that **MUST** carefully fit into the groove, one lower bowl and the small one which you will have to hang upside down to access up inside the filter head. (That's the one most people are not aware of) See important note below under Filters titled "Secondary" ref the fitting of the rubber sealing rings. Unfortunately it is not feasible to fill the new element with fuel so the air will have to be evacuated and replaced with fuel as part of the fuel bleeding process . This will be done with the hand primer pump.

**PURGING THE AIR WITH THE HAND PRIMER PUMP:** Don't be stingy when venting air and/or a mixture of air and fuel. The fuel system must be **completely** free of air in order for the injector pump to function properly. Any air in the pump will prevent it from developing enough pressure to "Pop" the injectors. The procedure for removing the air is critical. It is futile to just crank the engine and **hope** it will start. You are likely to end up frustrated and left with a smoking starter motor.

**BLEEDING THE INJECTOR PUMP:** 4.108/7 owners read note below. Locate the 2 bleed screws on the injector pump. You will require a 5/16" wrench to loosen or remove these. With your Ziploc bag and diaper in place for capturing the escaping fuel air mixture, operate the hand primer lever until you have air free fuel coming from the bleed screw/s, then close the air vent fittings. You should hear the escaping air as you operate the hand primer lever) eventually, each stroke of the lift pump primer lever should deliver a clean air free shot of fuel. Not until there are no visible air bubbles whatsoever should you proceed to the next stage. If the lift pump does not deliver fuel, it may be that the cam shaft lobe that operates the pump is at its peak, thus, preventing the hand primer from activating the pump's diaphragm. It will be necessary to rotate the engine approximately one revolution to relocate the cam position on the pump. Bumping the starter will re position the cam. You should feel the difference in the form of resistance on the primer lever.

Important. Do not over tighten these air vent screws on the pump as they are extremely delicate and seal with little pressure. They *will* break off easily, believe me, we've sold lots of them and there not cheap.



# Trans Atlantic Diesels, Inc.

*4.108/7 Owners, pay particular attention when bleeding the pump, the uppermost bleed screw which incorporates the anti-stall device. (as shown below) This fixture on some pumps is bonded into the housing and can easily break free, especially on older pumps. This will then leak profusely and render the engine un-serviceable. The repair is expensive and will require either a replacement housing or complete pump. For this reason I discourage opening the uppermost pump bleed screw. 99% of the time bleeding from the lower screw located a couple of inches below it on the pump will do the job.*

**STARTING THE ENGINE:** If you have bled the system following a routine maintenance filter change, it should not be necessary to vent the high pressure lines from the pump to the injectors. If, however, the engine shows reluctance to start, I suggest using a 5/8" wrench, to loosen any 2 high pressure line union nuts at the injector inlets. There is no harm in loosening all lines, this is optional. If you are bleeding an engine that ran out of fuel or injection components are being replaced, then you must loosen and bleed **all** the high pressure union line nuts at the injector inlets. **Caution:** Injection pressures develop around 3000 psi and much higher on newer engines, do not allow discharged fuel to contact skin. Crank the engine with the throttle at least 50% + open until fuel is discharged from the open lines, at which point tighten the line unions and proceed to start the engine as usual. Do not over crank the engine when attempting to start after bleeding. The starter motor should be allowed to cool for approx 60 seconds after each 15 second cranking period. If after a few tries the engine fails to start, you should turn off the sea cock to avoid back filling the engine with raw water. Remember to open the sea cock as soon as you are able to start the engine.

Low batteries, that restrict the cranking speed of the starter, may not only hinder your efforts in re starting the engine, but may cause harm to the starter. Make sure your batteries are in tip top shape before commencing. Unlike a spark ignited engine, a diesel relies on cranking speed to heat the air in the cylinders and ignite the fuel when it is injected. For this reason, good cranking speed is imperative.

**FUEL FILTER Secondary** (on engine filter) Replacing the filter elements on Perkins models, 4,108/7, 4.154, 4.236, 6.354, some Westerbeke models and any other engine using the element shown below. You have probably changed this filter numerous times but nevertheless you might find this tip useful. Your new Genuine Perkins filter should be supplied with 3 new rubber sealing rings. Many people don't bother changing these because it is easier to leave the old ones in place. The problem is they become brittle with age and are less likely to seal properly. That's why they are supplied with each filter. Particular attention should be paid to the largest sealing ring that fits into the groove in the top under side of the filter housing. In many cases, the old ring was not removed. If an attempt is made to fit the new ring with the old one in place, it will be forced downwards, blocking the fuel inlet side of the filter. *(as shown below)* This will prevent fuel from entering the element. It can fool you because it probably won't leak, but it won't work either. Many customers over the years have spent a lot of time and money trouble shooting fuel starvation after a filter change because of this misfit. The 3 sealing rings are different sizes and are located as shown below.



# Trans Atlantic Diesels, Inc.





# Trans Atlantic Diesels, Inc.

## **FUEL FILTER Primary** (Racor or similar off engine filter)

This filter is normally located between the main fuel tank and the engine's primer/lift pump. If the filter is fitted with fuel shut off valves on either side, it is advisable to close them when changing the element. Drain any water and sediment that may have collected in the bottom of the bowl and flush with some clean fuel. Install the new element and fill the bowl with clean fuel. Filling it eliminates air from entering the fuel system further up the line. Replace the filter cover and open the valves. Hopefully you will have prevented any air from entering the system. We highly recommend fitting a Vacuum gauge either on the primary filter, or in the line between the filter and the lift pump. This will monitor filter condition for you and prove to be a very worthwhile tool. We do offer such a gauge shown below mounted to a Racor 500.



**MICRON RATING ?** We suggest using either a 20 or a 30 Micron element in your Primary (Racor). Your engine filter (secondary) is normally a 20 Micron rating. This sequence will utilize both filter elements and more efficiently capture both large and small contaminants.

**THE IMPORTANCE OF CLEANLINESS:** Any work carried out on any of the engines fuel system components should be done with the upmost care to avoid even the slightest contamination. Once particles get in the system between the secondary filter and the injector pump, there is only one way out, that's injector nozzle. The orifices in the nozzle are many times smaller than the dia. of a human hair. It takes something that cannot even be detected visually to block or partially block an injector. Ironically many replacement injectors start life out partially blocked because of contamination during installation. When re-fitting injectors as well as high pressure and low pressure lines, it is recommended you clean the open fittings and threaded areas with a spray can of brake parts cleaner or similar. WD40 can be used in a pinch. When work is in process on the fuel system, keep all openings sealed and protected. If you don't have protective caps, silver foil is a good temporary alternative.



# Trans Atlantic Diesels, Inc.

**IMPORTANT INFORMATION: Racor 500 Filter Users:**

## Technical Bulletin Rubber Spacer for 2010 Elements

Beginning approximately July 2006 as a running change, Racor will add a rubber spacer, part number 15424, to all 2010 element gasket packs. The rubber spacer is designed for use with new style 2010 elements in **older** 500 Turbine Series housings. The spacer keeps the element elevated in the housing to prevent fuel bypass.

The illustrations below show where, when, and how the spacer should be used.

Rubber spacer NOT required for this style of housing.



Rubber spacer REQUIRED for this style of housing.

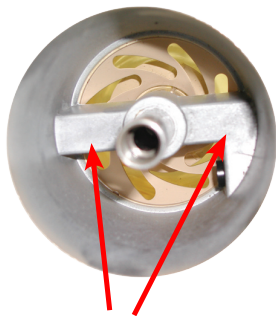

Has flat top surfaces.

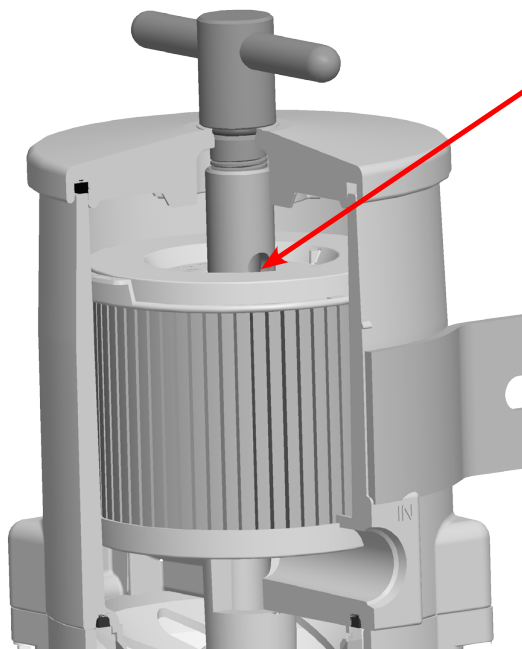
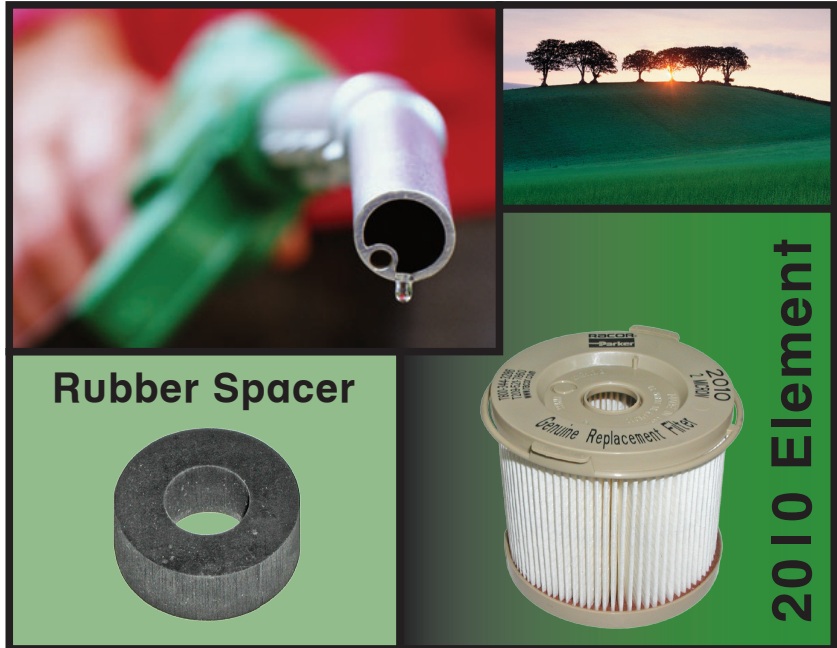

On older 500 Series units, the fuel outlet is exposed and fuel will bypass filter. On these models, install the rubber spacer on return tube first, then slide on filter.

On subsequent filter changeouts, leave the spacer inside the housing, it is not necessary to replace it.



# Trans Atlantic Diesels, Inc.

## IMPORTANT INFORMATION: Racor 500 Filter Users

THE THREE IMAGES BELOW ARE FROM THE PERKINS MANUAL

### ANTI-STALL DEVICE

#### S.I.G.M.A. Rotary type pump (TV8.510(M))

There is no anti-stall device incorporated in this type of fuel injection pump.

#### C.A.V. Rotary type pumps

(see figs. 13(c)(d) 4.107 and 4.108 engines).

- Slacken locknut (2) sufficiently to enable the anti-stall device body (1) to be unscrewed two complete turns.
- Adjust idling speed to 625 rev/min\* with idling adjustment screw (4).
- Screw down anti-stall device body (1) until there is a very slight increase in engine speed, bring back half a turn and lock with lock nut (2).
- Accelerate engine to maximum no load rev/min and immediately return to idling.

Should the period of return from maximum rev/min to idling exceed three seconds the device has been screwed in too far.

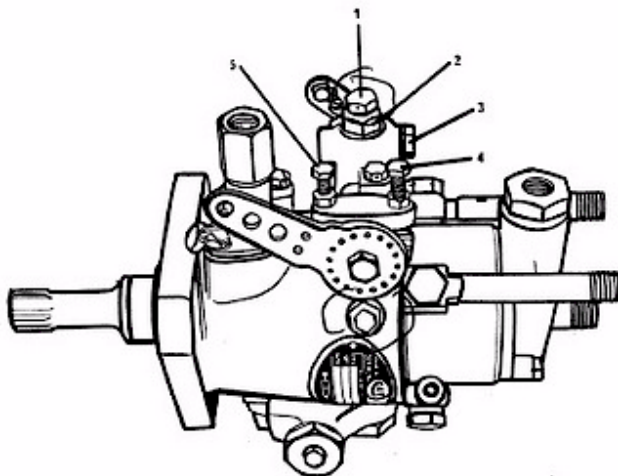

Fig. 13(c). Earlier Fuel Pump.

- |                                   |                          |
|-----------------------------------|--------------------------|
| 1. Anti-stall device body         | 4. Idle adjustment screw |
| 2. Anti-stall device body locknut | 5. Maximum speed screw   |
| 3. Air vent screw                 |                          |

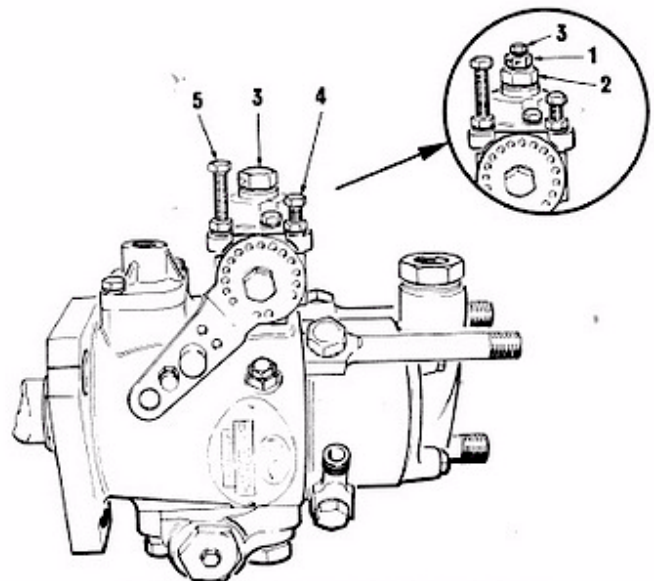

Fig. 13(d). Later Fuel Pump (anti-stall device shown inset).

- |                                    |                           |
|------------------------------------|---------------------------|
| 1. Anti-stall device body.         | 4. Idle adjustment screw. |
| 2. Anti-stall device body locknut. | 5. Maximum speed screw.   |
| 3. Air vent screw.                 |                           |

However should stalling occur, then the device has not been screwed in far enough. Therefore the necessary adjustment should be made to suit whichever is the case.

\*This idling speed may vary according to application. If in doubt, refer to one of the Perkins Distributors listed on pages 79 to 91.

#### In-line pumps (see fig. 13(e) V8.510 engine).

Screw out anti-stall device by two or three turns.

With engine warmed up, adjust idling speed to 500 rev/min, by means of idling adjustment screw.



# Trans Atlantic Diesels, Inc.

3. To avoid this trouble, it is advisable when all water has been drained to run the engine for a few seconds at idling speed, thus dispersing any moisture remaining in the pump.

After an anti-freeze solution has been used, the cooling system should be thoroughly flushed in accordance with the manufacturers instructions before refilling with normal coolant.

If the foregoing action is taken, no harmful effects should be experienced but Perkins Engines Ltd., cannot be held responsible for any frost damage or corrosion which may be incurred.

## fuel system

The importance of cleanliness in all parts of the fuel system cannot be overstressed. Dirt and sludge are killers to the engine life blood.

### FUEL OIL SPECIFICATION

The fuel oil used in Perkins Marine Engines should conform to the following specifications:—

#### United Kingdom

BS.2869 : 1967 — Class A1 and A2.

#### United States

A.S.T.M/D.975 — 66T — Nos. 1-D and 2-D.

Federal Specification VV - F - 800a : Grades DF-A, DF-1 and DF2 (according to operating ambient temperature).

#### Germany

DIN-51601 (1967).

#### France

J.O. 14/9/57 Gas Oil or Fuel Domestique.

#### Italy

Cuna-Gas Oil NC-630-01 (1957).

#### India

IS : 1460/1968 — Grade Special and Grade A.

#### Sweden

SIS. 15 54 32 (1969).

#### Switzerland

Federal Military Specification 9140-335-1404 (1965).

Fuel oils available in territories other than those listed above which are to an equivalent specification may be used.

## BLEEDING THE FUEL SYSTEM

Should the operator be unfortunate enough to run out of fuel, or whenever any part of the system between the fuel tank and fuel injection pump has been disconnected, the fuel system will have to be bled.

### Engines fitted with C.A.V. DPA rotary type fuel injection pumps

Ensure there is sufficient fuel in tank and that the fuel tank cock, where fitted, is turned on.

1. Slacken air vent valve on side of control gear housing (see figs. 10(a)(b)(c)). For later engines see fig. 13(d).
2. Slacken vent valve fitted on one of the two hydraulic head locking screws (see figs. 10(d)(e)(f)). Unscrew vent plug on top of fuel filter where fitted.
3. Operate priming lever on fuel feed pump (if this is not possible, the camshaft driving the lift pump lever may be on maximum lift; turn engine one revolution) and when fuel, free from air bubbles, issues from each venting point, tighten the screws in the following order:—
  1. Fuel filter cover vent screw.
  2. Head locking screw.
  3. Governor vent screw.
4. Slacken the pipe union nut (see figs. 10(g)(h)(j)) at the pump inlet, operate the priming lever and retighten when fuel, free from air bubbles, issues from around the threads.
5. Slacken unions at atomiser ends of two of the high pressure pipes.

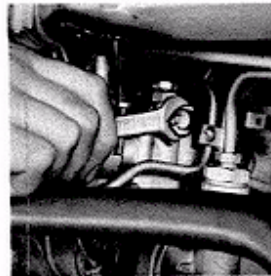

Fig. 10(a). 4.107 and 4.108  
(for later engines see fig. 13(d)).

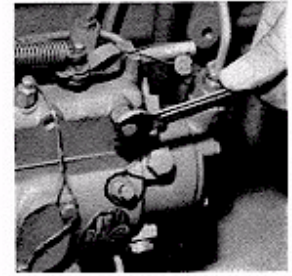

Fig. 10(b). 4.236.



# Trans Atlantic Diesels, Inc.

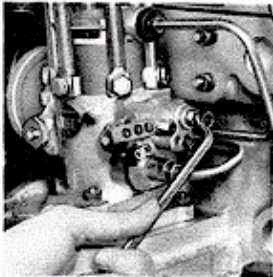

Fig. 10 (c) 6.354.

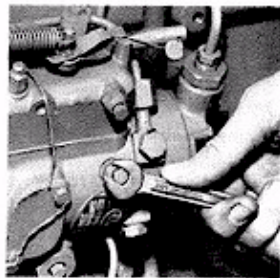

Fig. 10(e). 4.236.

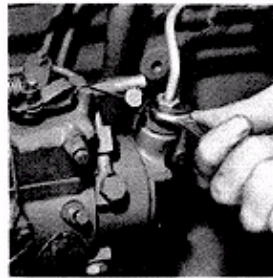

Fig. 10(g). 4.236.

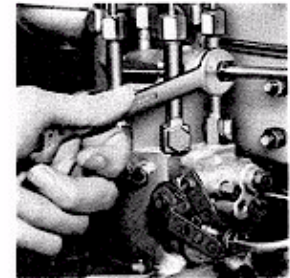

Fig. 10(j). 6.354.

6. Set accelerator to the fully open position ensuring that the stop control is in the "run" position.
7. Turn engine until fuel, free from air bubbles, issues from both fuel pipes.
8. Tighten the unions on both fuel pipes, and the engine is ready for starting. In the unhappy event of the batteries becoming flattened during the above operation, look to your flare locker (did you check its contents before leaving port?). If in any doubt about battery condition the load on the battery can be eased during cranking by preventing air being drawn into the air intake. Remove air filter and close off intake by pressing a large sheet of stiff cardboard or similar over intake, or remove atomisers.

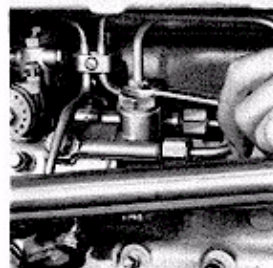

Fig. 10(h). 4.107 and 4.108.

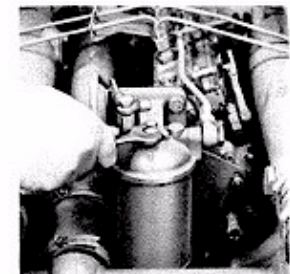

Fig. 11(a)

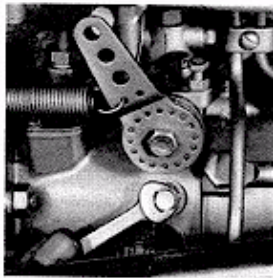

Fig. 10(d). 4.107 and 4.108

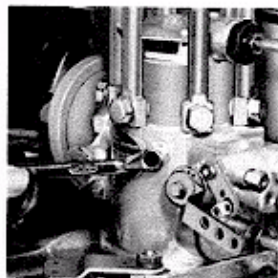

Fig. 10(f). 6.354.

## Engines fitted with in-line fuel injection pumps

1. Unscrew final filter vent plug (see fig. 11(a)).
2. Unscrew the two vent plugs or vent screws on the fuel injection pump by two or three turns. These plugs are fitted each side of the fuel inlet connection on the right hand side of the pump (see figs. 11(b)(c)).
3. Operate priming lever on the fuel lift pump. If the lift pump driving cam is on maximum lift, it will not be possible to operate the hand primer. If so, turn the engine through one revolution.

When fuel, free from air bubbles, issues from the venting points, tighten the fuel filter vent plug and then the fuel injection pump vent plugs.

52

53

## Typical Perkins 4.108/7 Injector Pump (Hydraulic Governor Style)

