

# ZF 25 A

## TECHNICAL DATA SHEET

---

### ZF 25 SERIES PRODUCT DETAILS



#### Description

- Reverse reduction marine transmission with hydraulically actuated multi-disc clutches
- Suitable for high performance applications in luxury motoryachts, sport fishers, express cruisers etc
- Robust design also withstands continuous duty in workboat applications
- Fully works tested, reliable and simple to install
- Design, manufacture and quality control standards comply with ISO 9001
- Compatible with all types of engines and propulsion systems, including waterjets and surface- piercing propellers, as applicable

#### Features

- Lightweight and robust aluminum alloy casing (sea water resistant)
- Case hardened and precisely ground gear teeth for long life and smooth running
- Output shaft thrust bearing designed to take maximum propeller thrust astern and ahead
- Smooth and reliable hydraulic shifting with control lever for attachment of push-pull cable
- Suitable for twin engine installations (same ratio and torque capacity in ahead or astern mode)
- Replaceable oil filter cartridge
- Compact, space saving design due to 8° down-angle and beveloid gear principle



# ZF 25 A

## RATINGS

Ratios	Power Factor		Input Power Capacity						Max. kW	Max. hp	Max. RPM
	kW/RPM	hp/RPM	kW	hp	kW	hp	kW	hp			
Pleasure Duty - Diesel			3000 RPM		3600 RPM		3800 RPM				
1.548, 1.926	0.0325	0.0436	98	131	117	157	124	166	179	240	5500
2.480*	0.0277	0.0371	83	111	100	134	105	141	152	204	5500
2.292	0.0262	0.0351	79	105	94	126	100	133	144	193	5500
2.714	0.0251	0.0337	75	101	90	121	95	128	138	185	5500
Pleasure Duty - Gasoline			3000 RPM		3600 RPM		3800 RPM				
1.548, 1.926	0.0325	0.0436	98	131	117	157	124	166	179	240	5500
2.480*	0.0277	0.0371	83	111	100	134	105	141	152	204	5500
2.292	0.0262	0.0351	79	105	94	126	100	133	144	193	5500
2.714	0.0251	0.0337	75	101	90	121	95	128	138	185	5500
Light Duty - Diesel			2100 RPM		2500 RPM		2800 RPM				
1.548, 1.926, 2.292, 2.480*	0.0249	0.0334	52	70	62	84	70	94	137	184	5500
2.714	0.0239	0.0321	50	67	60	80	67	90	131	177	5500
Medium Duty - Diesel			2100 RPM		2500 RPM		2800 RPM				
1.548, 1.926, 2.292, 2.480*	0.0213	0.0286	45	60	53	72	60	80	117	157	5500
2.714	0.0203	0.0272	43	57	51	68	57	76	112	150	5500
Continuous Duty - Diesel			1800 RPM		2100 RPM		2400 RPM				
1.548, 1.926, 2.292, 2.480*	0.0172	0.0231	31	42	36	49	41	55	55	74	3200
2.714	0.0166	0.0223	30	40	35	47	40	54	53	71	3200

\* Special Order Ratio

# ZF 25 A

## DIMENSIONS

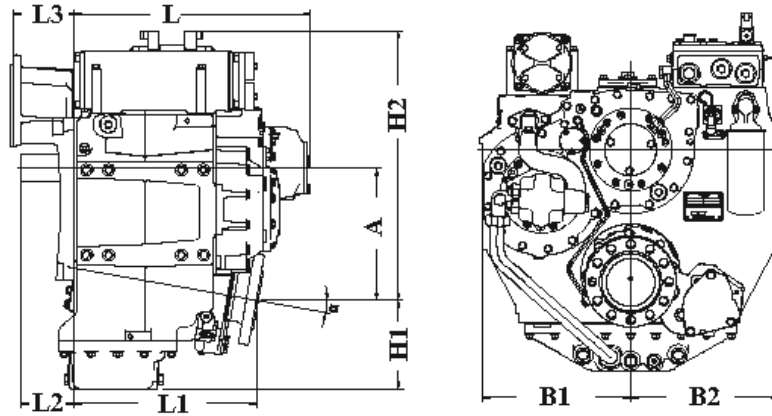

A	B1	B2	H1	H2	L0	L1	L2
Millimeter (mm)							
115.3	147.0	147.0	75.0	228.0	293.0	216.0	82.5
Inch (in)							
4.54	5.79	5.79	2.95	8.98	11.54	8.5	3.25
Angle (°)	Weight (kg)		Weight (lb)		Amount of Oil (l)		Amount of Oil (qt)
8	24		53		1.8		1.9

## BELL HOUSING DIMENSIONS

Name	A		B		C		L3		Bolt Holes		
	mm	in	mm	in	mm	in	mm	in	No.	Diameter	
										mm	in
SAE 3	409.58	16.13	428.63	16.88	450.85	17.75	29.0	1.14	12	10.32	0.41
SAE 4	361.95	14.25	381.0	15.0	403.23	15.88			12	10.32	0.41
SAE 5	314.33	12.38	333.38	13.13	355.6	14.0			8	10.32	0.41
B/W							17.5	0.69			
Yanmar JH											

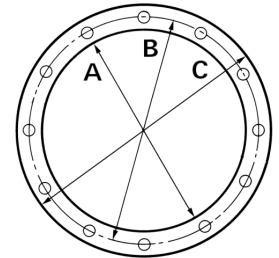

## OUTPUT FLANGE DIMENSIONS

A		B		C		D		Bolt Holes		
mm	in	mm	in	mm	in	mm	in	No.	Diameter (E)	
									mm	in
102.0	4.02	82.5	3.25	63.5	2.5	10.0	0.39	4	11.5	0.45

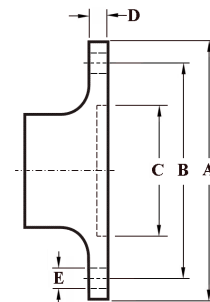

# GENERAL INFORMATION

---

## Duty Definitions

### Pleasure Duty

Highly intermittent operation with very large variations in engine speed and power.

Average engine operating hours limit:	500 hours/year 300 hours/year for mechanical gearboxes
Typical hull forms:	Planing
Applications:	Private, non-commercial, non-charter leisure activities, no racing

### Light Duty

Intermittent operation with large variations in engine speed and power.

Average engine operating hours limit:	2500 hours/year (for hydraulic transmissions smaller than ZF 2000 series, 2000 hours/year)
Typical hull forms:	Planing and semi-displacement
Typical applications:	Private and charter, sport/leisure activities, naval and police activities

### Medium Duty

Intermittent operation with some variations in engine speed and power.

Average engine operating hours limit:	4000 hours/year (for hydraulic transmissions smaller than ZF 2000 series and workboat ZF W2700 series, 3500 hours/year)
Typical hull forms:	Semi-displacement and displacement
Typical applications:	Charter and commercial craft (example: crew boats), and naval and police activities

### Continuous Duty

Continuous operation with little or no variations in engine speed and power.

Average engine operating hours limit:	Unlimited
Typical hull forms:	Displacement
Typical applications:	Heavy duty commercial vessels

---

## Technical Notes

### Duty Ratings

Ratings apply to marine diesel engines at the indicated speeds. At other engine speeds, the respective power capacity (kW) of the transmission can be obtained by multiplying the Power/Speed ratio by the speed. Approximate conversion factors:

- 1 kW = 1.36 metric hp
- 1 kW = 1.34 U.S. hp (SAE)
- 1 U.S. hp = 1.014 metric hp
- 1 Nm = 0.74 lb.ft.
- 1 Kg = 0.454 lb

Ratings apply to right hand turning engines, i.e. engines having counterclockwise rotating flywheels when viewing the flywheel end of the engine. These ratings allow full power through forward and reverse gear trains, unless otherwise stated. Contact your nearest ZF Sales and Service office for ratings applicable to gas turbines, as well as left hand turning engines, and marine transmissions for large horsepower capacity engines. Ratings apply to marine transmissions currently in production or in development and are subject to change without prior notice.

**NOTE:** The maximum rated input power must not be exceeded (see respective ratings in the technical data sheets).

### Safe Operating Notice

The safe operation of ZF products depends upon adherence to technical data presented in our brochures. Safe operation also depends upon proper installation, operation and routine maintenance and inspection under prevailing conditions and recommendations set forth by ZF. Damage to transmission caused by repeated or continuous emergency manoeuvres or abnormal operation is not covered under warranty. It is the responsibility of users and not ZF to provide and install guards and safety devices, which may be required by recognized safety standards of the respective country (e.g. for U.S.A. - the Occupational Safety Act of 1970 and its subsequent provisions).

### Monitoring Notice

The safe operation of ZF products depends upon adherence to ZF monitoring recommendations presented in our operating manuals, etc. It is the responsibility of users and not ZF to provide and install monitoring devices and safety interlock systems as may be deemed prudent by ZF. Consult ZF for details and recommendations.

### Survey Society Classification

In most cases, the maximum medium and continuous duty ratings permitted by ZF are accepted in full by major classification societies. If classification is required, contact ZF regarding proper procedures (also for yacht service and ice classifications service).

### Dimensions and Weights

Dimensions and weights refer to transmissions with bell housing (where appropriate) but excluding options such as: trolling valves, power take-offs, propeller shaft companion flanges, torsional couplings etc.

---

## Torsional Vibration and Torsional Couplings

The responsibility for ensuring torsional vibration compatibility rests with the overall propulsion system integration responsible party.

Compatibility check of torsional vibration must include excitations induced by engine governor. ZF cannot accept any liability for gearbox noise or for damage to the gearbox, the flexible coupling or to other parts of the drive unit caused by torsional vibrations. Contact ZF for further information and assistance.

For single engine powered boats, where loss of propulsion can result in loss of control, ZF recommends the use of a torsional limit stop. It is the buyer's responsibility to specify this option. ZF cannot accept any liability for personal injury, loss of life or damage or loss of property due to the failure of the buyer to specify a torsional limit stop.

ZF selects torsional couplings on the basis of nominal input torque at commonly rated engine speeds. Consult ZF for details concerning speed limits of standard offered torsional couplings, which can be below transmission limits. Special torsional couplings may be required for Survey Society requirements.